



CE
ISO9001



Mechanical Life



Degree
of protection

LIMIT SWITCH

SE-XCK-M121



TECHNICAL DETAILS

Double Break Mechanism	INO +INC Force Break snap action
Rated Voltage/Current	10 (4) A, 125, 250 VAC/6(2)A, 380VAC
Contact Resistance	25m Ω max
Insulation Resistance	100m Ω min
Dielectric Strength	1000 VAC 50/60 Hz for 1 minute between terminals of the same polarity 1500 VAC 50/60 Hz for 1 minute between current carrying and non-current carrying metal parts 1500 VAC 50/60 Hz for 1minute, between each terminal and ground
Electrical Life	500,000 at 10A 250VAC Resistive
Mechanical Life	10,000,000 operations min
Operating Speed	5mm/s to 0.5m/s
Degree of Protection	IP 65
Ambient Temperature Rised	Max 30° C over ambient temperature at rated voltage/current
Conformed Standards	Cenelec EN 50041, EN 50047, IEC 337-1, VDE 0660
Operating temperature	-5° C ~ + 65° C
Storage Temperature	-5° C ~ + 65° C
Ambient operating Humidity	95% RH Max
Shock Resistance	Mechanical Durable: 1000m/s ² min Malfunction 300m/s ² min
Vibration Frequency	Malfunction 10 to 55 Hz, 1.5mm double amplitude
Terminal Screw Torsional Force	6-8 kgf-cm
Other Screw Torsional Force	Cover 12-14 kgf -cm/Head 8-9 Kgf-cm/Mounting 50-60 kgf/cm
Bare Wire Diameter	2 Max
Cable Diameter	12 Max



Operating Characteristics

Operating Force	4.9 N
Release Force	0.98 N
Pre-travel	20°
Tripping Position	22.5°
Movement Differential	10°
Over Travel	75°
Total Travel	95°
Rotary indexing	22.5°

Dimension

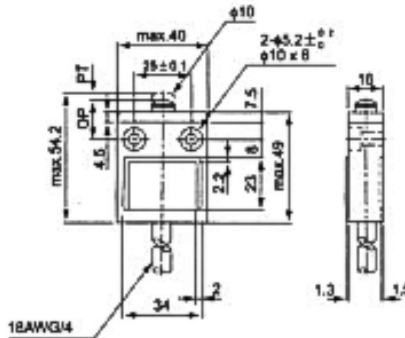

Contact Form

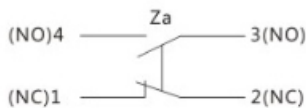

Features

- Economical & Plastic type
- Stainless steel roller, punch and spring
- Swing amplitude, extra large + 95°
- M20x1.5 cable gland that can be equipped